

Zato

Scrap Processing Solutions



Twin-shaft shredder
Pre shredder

BLUE DEVIL

FAST POWERFUL PROFITABLE



www.zatoshredder.com

MORE VALUE TO YOUR SCRAP



METAL
RECYCLING



STEEL MILLS



AUTO
RECYCLING



ALUMINIUM
FOUNDRIES



CAR
MANUFACTURERS



CLOUD REMOTE
MONITOR

BLUE DEVIL

Twin-shaft shredder
Pre shredder

THE GREAT ADVANTAGE OF HAVING A **BLUE DEVIL** IS THE HUGE **VALORISATION** THAT IS GIVEN TO SCRAP, WHICH ACQUIRES.

- **MORE DENSITY • HOMOGENEITY**

A POWERFUL **VALORIZER**

Blue Devil is the only shredder on the market which is specifically developed for the ferrous scrap processing.

- The main processable materials are:
- Bulk and **bundled** mixed scrap from collection;
- White goods like fridges, washing machines...;
- Cars, bulk and in bundles [with mechanics and motor];
- Trimmings from rolling mill and industrial scrap;
- Voluminous sheets;
- Reinforcing rebar;
- Flame cut steel;
- Bulk scrap;
- Tanks, closets, etc...

Steel mills need to buy homogenous and very dense scrap.

A Blue Devil is the only machine available on the market which allows the widest range of ferrous and non-ferrous scrap getting equivalent dimension and dramatically increasing its density.

That is the reason why scrap processed with a Blue Devil is so much valued by steel mills, which pay more for it than for scrap sheared with a standard shear baler.

Scrap processed with a Blue Devil can also be much better cleaned with a separation line, being the material loose and not wrapped. This is another point valued by steel mills, which need to meet environmental requirements.

AN EFFICIENT **VALORISATOR**

All materials designed to the hammer mill – entire cars, bundled cars with mechanics and motors, mixed scrap from collection in bundles, bulk scrap in general, ...- can be prepared for further milling with Blue Devil pre-shredder.

When the hammer mill receives prepared material, its production increases up to 30%.

The hammer mill is also preserved from damages caused by unshreddable blocks which can be involuntarily introduced and works in full safety, enlarging its lifetime and reducing costs for spares.



SHAFTS

On the two shafts, made of special high quality steel, are mounted the cutting blades.

Cutting blades are made of a specific high resistance material, which increases the lifetime. Their geometry is studied in order to maintain a perfect intersection between the two shafts and a fast positioning in the blades seat.

Blades disposition is customized according to the scrap to be processed, both to increase performances and to preserve the machine from excessive stresses, thus granting a superior lifetime.

Blades can have different dimensions: 150, 200 and 300 mm. All raw materials, components and production processes have quality certifications.

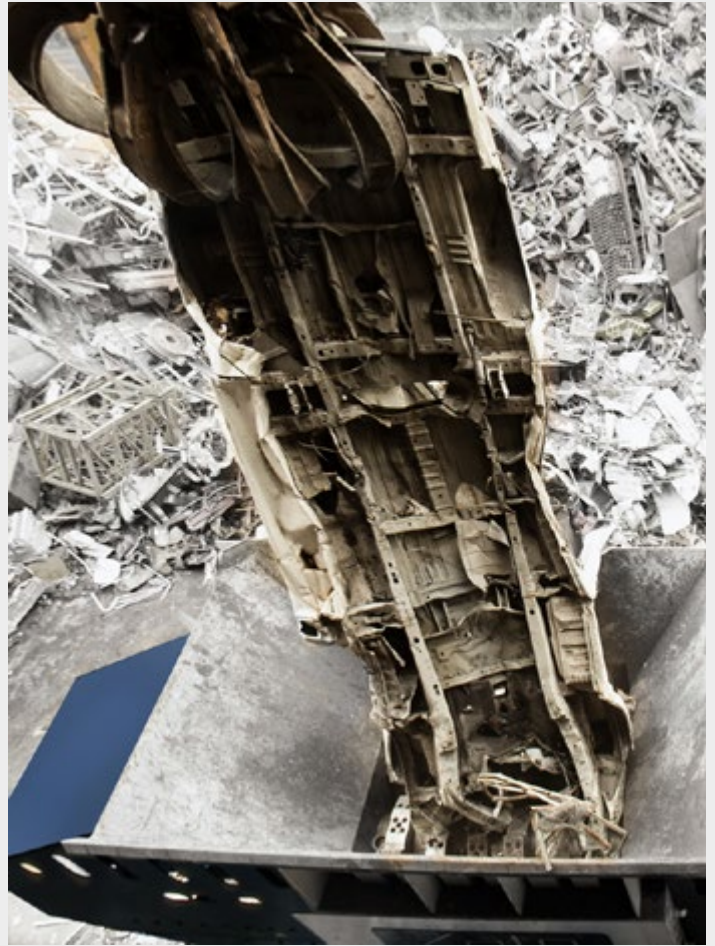

CONTAINER

Containers enclose: engine, hydraulic unit, hydraulic pump, electric panel.

The container has an optimal resistance to any weather conditions and is completely sound proof.

Made of galvanized steel sandwich panels, with high density mineral fiber insulation and reinforced floor, fire resistant REI 120. Noise level: 70 dB at 7 mt. distance.

Service door with panic exit bar, main door. Internal lighting.



CONTAINER 40" mm. 12.120 X 2.450 X 2800 (MOTORE ELETTRICO CON INVERTER).

MOTORS AND ENGINES

All models can be driven by diesel or electrical motors.



SAFETY AND COMMANDS

Each Blue Devil is equipped with safety devices which are immediately in the wings whenever needed and help the operator to limit any damage to the machine and to preserve it.

Whenever any uncrushable object falls in, the PLC orders the shafts 3 inversions.

An acoustic signal is also activated.

On all models is also possible to install the Web Remote Survey, the remote control which allows to control, command and produce diagnostics on operation.

In case of any need, Web Remote Survey is specifically developed to control our plants from remote, thus allowing ZATO to identify immediately the problem and make the intervention in a faster and more precise way.



BLUE DEVIL

GF1500

GF4000

GF5000

GF6000

		GF1500	GF4000	GF5000	GF6000
Main Body	Tonn.	36	42	51	60
Feeding hopper	Tonn.	4,6	5	3,9	5,2
Supporting structure	Tonn.	7	7	10+6 [Carter]	11+6,7 [Carter]
Hopper capacity	m3	7	7	8	12
Shafts	Nr.	2	2	2	2
Blades 150 mm.	Nr.	84	84	-	-
Blades 160 mm.	Nr.	-	-	84	-
Blades 200 mm.	Nr.	60	60	-	60
Blades 300 mm.	Nr.	-	84	-	-
Safety inversions	Nr.	3	3	3	3
Engine power	cv	571	672	639,2	789
Engine power	kW	420	494	470	580
Engine speed	Giri/min.	1800	1800	1480	1480
Hourly production*					
*Mixed collection scrap and cars, baled and bulk, flame cut steel	Tonn/ora	15/25	20/25	20/40	30/50**
**Hourly production Aluminum: slag, bales, sheets	Tonn/ora	5/10	-	-	15/20



MAGNETIC SEPARATION LINE

A magnetic separation line placed after a Blue Devil twin-shaft shredder allows the recovery of non-ferrous metals present in mixed collection scrap and cars. This widens the possibility of earning profits from scrap, both selling these metals separately and cleaning more thoroughly ferrous material. Ferrous scrap, better cleaned, gets more value in the steel mill.

Almost all metals can be collected and not a single penny is lost. Composed of: vibrating plan [01], magnetic drum [02], conveyor belt for steel [03], conveyor belt for metals [04], overbelt [05] on the conveyor belt for steel for a deeper cleaning.

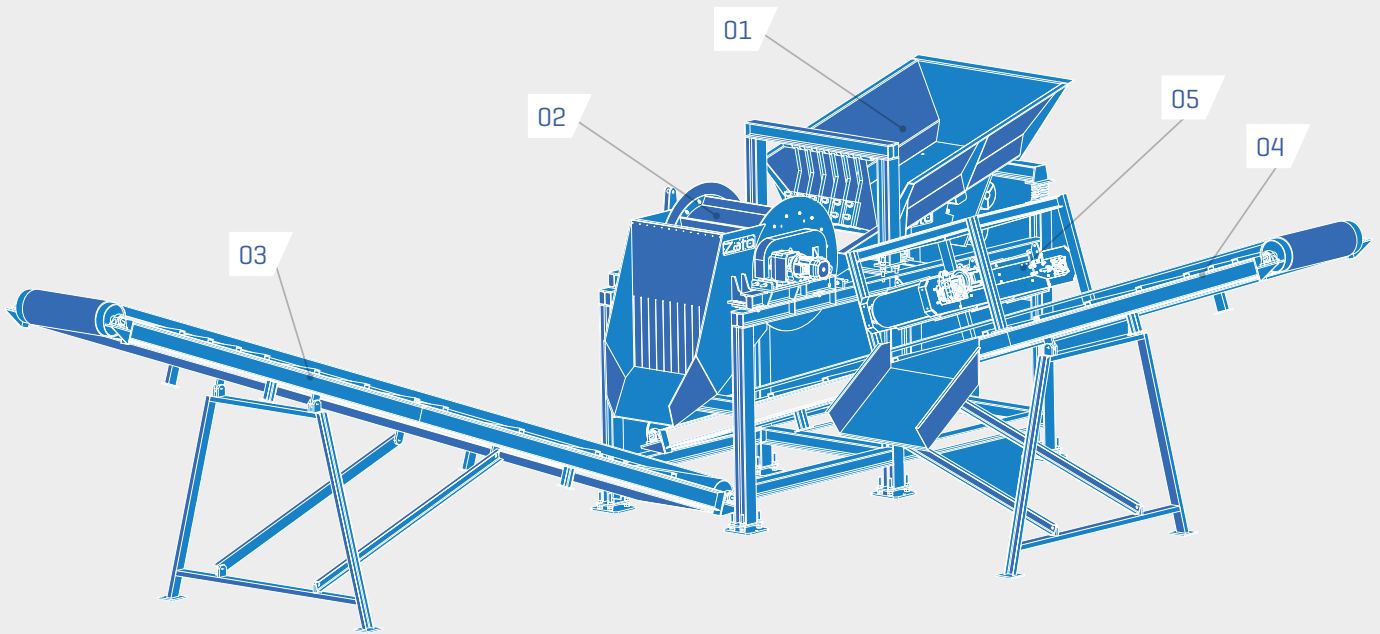

ZATO S.R.L.

Via Campi Grandi, 23
25080 PREVALLE (BS) - Italy

ph. +39 [0]30 6461800 r.a.
fax +39 [0]30 6801897

BLUE DEVIL

