

HAMMER MILL DRAKE/16

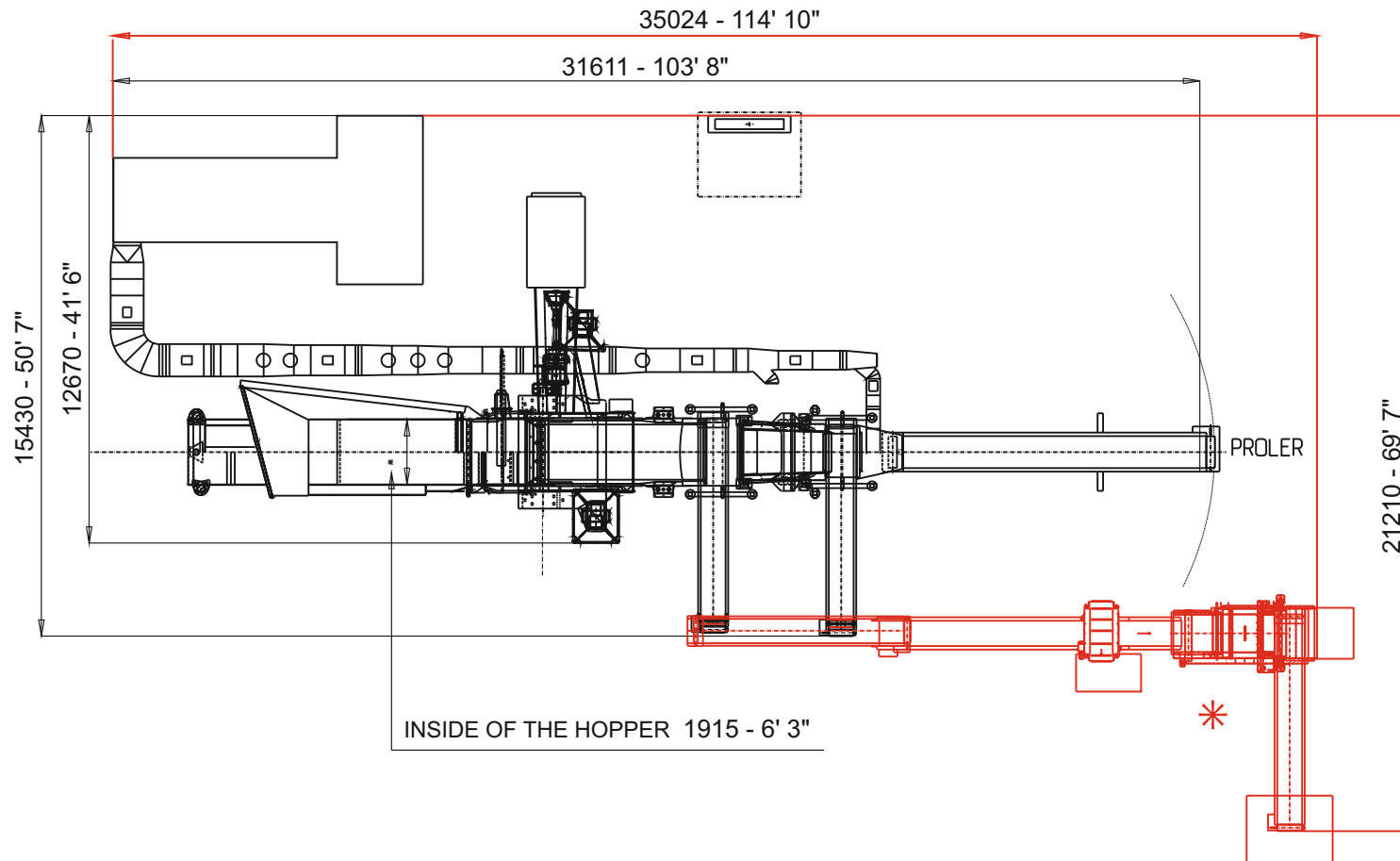
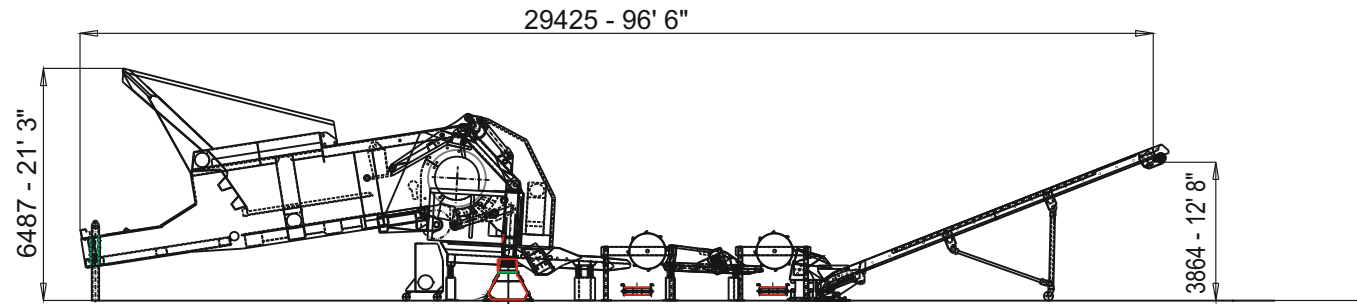
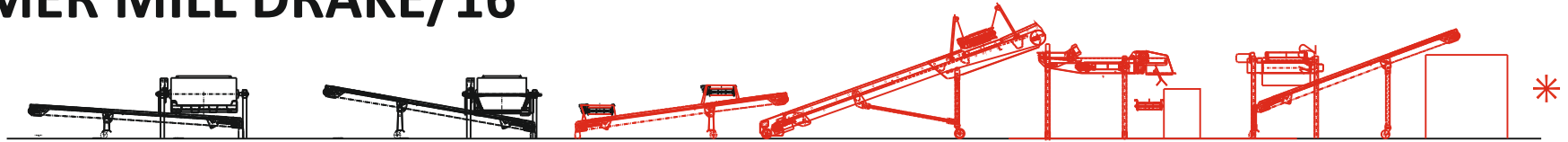

HAMMER MILL DRAKE/16

Standard diesel engine or electrical motor	750 Kw
Diesel fuel consumption ~	70,75 l/h - 20÷22 gal/h
Productivity \cong	20÷25 ton/h
* Optional: noble metals separator (ECS)	
The positioning of the rolling magnets and conveyors can be adjusted on the basis of special requests	

Ing. BONFIGLIOLI s.p.A. 40050 Castello d'Argile - BOLOGNA – ITALIA

Email: service@ingbonfiglioli.it Web: www.ingbonfiglioli.it

Tel. +39.051.6867214 Fax +39.051.6867222