

# Ing. BONFIGLIOLI S.p.A.

Via S.Andrea 11 – 40050  
Castello d'Argile (BO)- ITALY  
Tel.: +39 051 6867214  
Fax.: +39 051 6867222  
Website: [www.ingbonfiglioli.it](http://www.ingbonfiglioli.it)  
Email: [service@ingbonfiglioli.it](mailto:service@ingbonfiglioli.it)



## DRAKE 10-12-16 HAMMERS COMPACT SHREDDING SYSTEM



### Technical Data

<ul style="list-style-type: none"> <li>Shredder available in 4 different versions:</li> </ul>	10-12-16 hammers
<ul style="list-style-type: none"> <li>Max RPM:</li> </ul>	850/900 – 10 & 12 hammers 900/950 – 16 hammers
<ul style="list-style-type: none"> <li>Engines available:</li> </ul>	Diesel (CUMMINS or CAT 600 to 1000 HP) or Electric (VEM 500 to 750 KW)
<ul style="list-style-type: none"> <li>Footprint required for the installation:</li> </ul>	10 & 12 hammers version: 15m X 37 m 16 hammers version: 16m X 40 m
<ul style="list-style-type: none"> <li>Hammer Weight:</li> </ul>	10 hammers version: 110 kg 12 hammers version: 120 kg 16 hammers version: 163 kg
<b>Working Cycle</b> <ul style="list-style-type: none"> <li>Automatic – a complete shredding cycle</li> </ul>	180 seconds
<b>Filtering system</b> <ul style="list-style-type: none"> <li>Water filtering dust collection system</li> </ul>	20 ppm
<b>Productivity</b> <ul style="list-style-type: none"> <li>10 hammers – suitable for pre-sheared material</li> <li>12 hammers – suitable for loose material</li> <li>16 hammers – suitable for vehicles</li> </ul>	10-13 tons/hour 15-18 tons/hour 22-25 tons/hour
<ul style="list-style-type: none"> <li>Proll or shred density (<u>ferrous production</u>)</li> </ul>	0.90- 1.00 tons/cubic meter (adjustable with the grids change)
<ul style="list-style-type: none"> <li>Equipped with its own Eddy Current Separator (optional) for the <u>non-ferrous material</u> collection</li> <li>Availability for a Double Eddy Current Separator System (optional)</li> </ul>	10 & 12 hammers: length 660 mm -2 posts 16 hammers: length 1040 mm -2 posts

# Ing. BONFIGLIOLI S.p.A.

Via S.Andrea 11 – 40050  
Castello d'Argile (BO)- ITALY  
Tel.:+39 051 6867214  
Fax.:+39 051 6867222

Websiste: [www.ingbonfiglioli.it](http://www.ingbonfiglioli.it)  
Email: [service@ingbonfiglioli.it](mailto:service@ingbonfiglioli.it)



## Maintenance

- Greasing (automatic) daily
- Standard service for a diesel engine
- Standard bearings lubrication
- Replacement of the filtering juta/plastic bags

**Spare Parts:** Available upon customer request

- |               |                       |
|---------------|-----------------------|
| • Hammer life | 280-300 working hours |
| • Pin life    | 500-550 working hours |

## Cost Savings

- Low capital/high production investment
- Low operating costs
- Low fuel consumption
- Reduced labour costs

## Greater Mobility and Versatility

- Set-up and installation in 15 days max.
- Simple design and construction
- High performance compact shredder
- Easy maintenance
- Minimal concrete pad required – 40 cm



# Ing. BONFIGLIOLI S.p.A.

Via S.Andrea 11 – 40050  
 Castello d'Argile (BO)- ITALY  
 Tel.:+39 051 6867214  
 Fax.:+39 051 6867222  
 Websiste: [www.ingbonfiglioli.it](http://www.ingbonfiglioli.it)  
 Email: [service@ingbonfiglioli.it](mailto:service@ingbonfiglioli.it)

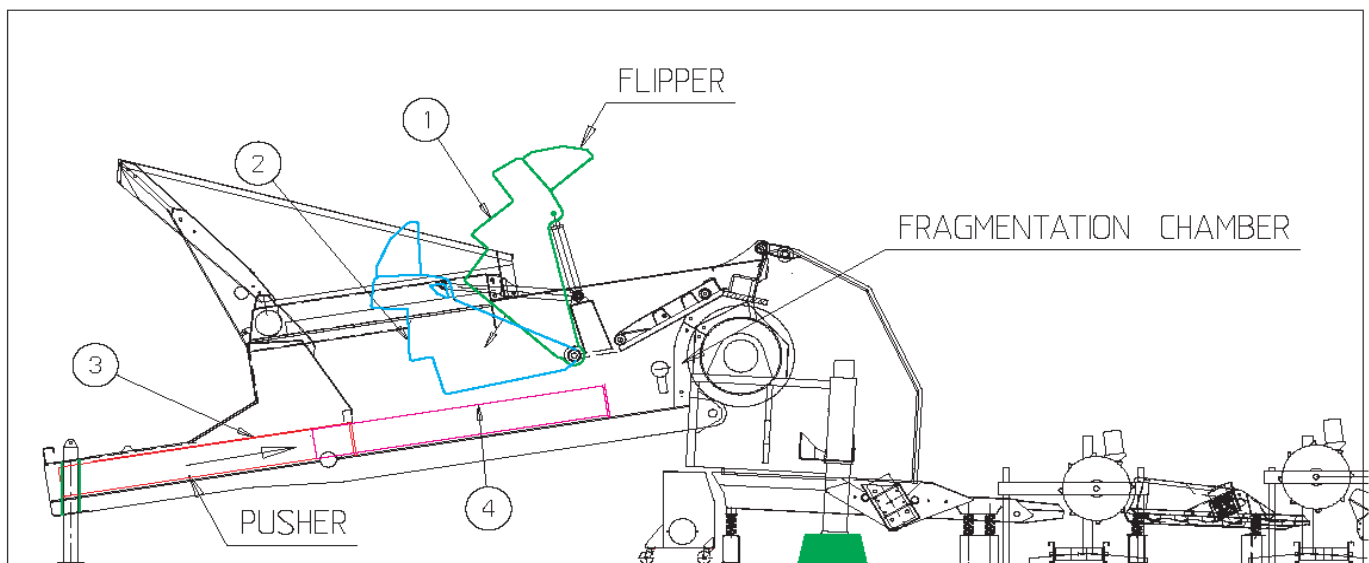

OPERATION SEQUENCE (AUTOMATIC RUNNING):  
 <1> FLIPPER IOPER AND PUSHER IS NON WORKING POSITION <3>  
 <2>FLIPPER CLOSED , MICROSWITCH ENGAGED THE PUSHER FORWARDING <4>  
 AND PUSHING THE MATERIAL INTO THE FRAGMENTATION CHAMBER

 40050 CASTELLO D'ARGILE BOI ITALIA		LISTA DEI RISPETTIVE PER DIMENSIONI LARGHEZZE SERIE TOLLERANZA RILEVATA	
		OPERAZIONI	TOLLERANZA
Denominazione: MULINO DRAKE 2000 WORK SEQUENCE	Stato: Data:	da 1 a 10 ± 0,10 da 10 a 20 ± 0,15 da 20 a 30 ± 0,20 da 30 a 50 ± 0,30 da 50 a 100 ± 0,40 oltre 100 ± 0,50	da 1 a 10 ± 0,10 da 10 a 20 ± 0,15 da 20 a 30 ± 0,20 da 30 a 50 ± 0,30 da 50 a 100 ± 0,40 oltre 100 ± 0,50
Il presente allegato è in ininterrotta costante serie di stampa della BONFIGLIOLI SpA. Le operazioni e le tolleranze sono valide a meno di legge		Codice:	